

CHEMICAL CW LASERS WITH AN EXTENDED ACTIVE MEDIUM

I. A. Fedorov, S. V. Konkin,
V. K. Reboné, M. A. Rotinyan,
A. A. Belyaev, and Yu. P. Maksimov

UDC 621.378:535

We consider the principal results of the investigations of the last few years on increasing the lasing length of supersonic continuous chemical HF lasers by additionally diluting the active medium with an inert gas by feeding helium into different regions of the nozzle and active medium. The investigations were carried out with the use of models of HF lasers equipped with nozzle units of three different designs based on a three-jet scheme of mixing components. In the course of the investigations, active media with a length of up to 12.5 cm with a high optical quality providing high energy characteristics of the laser have been obtained, and for the first time a large-aperture output beam with a cross section close to a square one measuring 10×11 cm has been realized.

Introduction. The nozzle unit of the supersonic continuous chemical HF laser (HF CCL) is the key element of its gas-dynamic channel. One of the main functions of the nozzle unit is the mixing of fuel components — oxidizing gas (containing fluoride atoms) and secondary fuel (hydrogen molecules) jets — with subsequent initiation of chemical reactions of pumping in the optical cavity. The process of mixing of components should be organized so that a combination of a high energy efficiency of the laser operation on the one hand and an acceptable optical quality of the active medium at its maximum length on the other is provided. Simultaneous realization of all these requirements is a difficult task. Indeed, the high energy efficiency of the CCL operation is due to the intensification of the process of mixing the jets of the components introducing considerable perturbations into the active medium, which affects its optical quality. Unlike gas-dynamic lasers [1], the process of intense mixing in the CCL leads to a decrease in the lasing length and a nonuniform radiation intensity distribution along it, and, accordingly, to an increase in the radiation load on the cavity mirrors. A small lasing length raises the diffraction limit of laser radiation divergence, and a high beam load on the cavity optics leads to its thermal deformation, which in turn affects the increase in divergence. Therefore, the design of nozzle units of CCLs is based on a compromise between the desire to have a high specific energy output and the necessity of searching for ways of decreasing perturbations in the active medium and increasing the lasing length.

In traditional HF CCLs with a two-jet nozzle unit based on the nozzle–nozzle scheme and realizing the diffusion mechanism of mixing jets of components, the lasing length, within certain limits, can be changed by varying such laser parameters as cavity pressure, quantity of secondary fuel, geometrical degree of flaring out of nozzles, and spacing between nozzles. However, the calculations and experiments performed by us have shown that by varying these parameters we cannot obtain a lasing length exceeding 5 cm without considerable losses in the specific energy output.

One approach to the solution of this problem permitting us to obtain a much greater increase in the lasing length of HF CCLs is the use of the three-jet principle of mixing components, which involves spatial separation of the oxidizing gas and secondary fuel jets by an inert gas (usually helium) layer playing the role of an additional (secondary) diluent. The main consequences of such an approach are a decrease in the diffusion rates of the secondary fuel jets into the oxidizing gas, proceeding of the reactions of pumping and relaxation of vibrational energy, a decrease in the translational temperature of the active medium, and, as a result of this, preservation of inversion at a larger length. Moreover, the presence of a helium interlayer permits "initiating" the pumping reaction at various distances from the exit section of the nozzle unit and controlling the lasing length. It also favors a more uniform intensity distribution along the lasing region.

Russian Scientific Center "Applied Chemistry," St. Petersburg, Russia; email: polya@mail.ru. Translated from *Inzhenerno-Fizicheskii Zhurnal*, Vol. 75, No. 2, pp. 177–184, March–April, 2002. Original article submitted May 4, 2001.

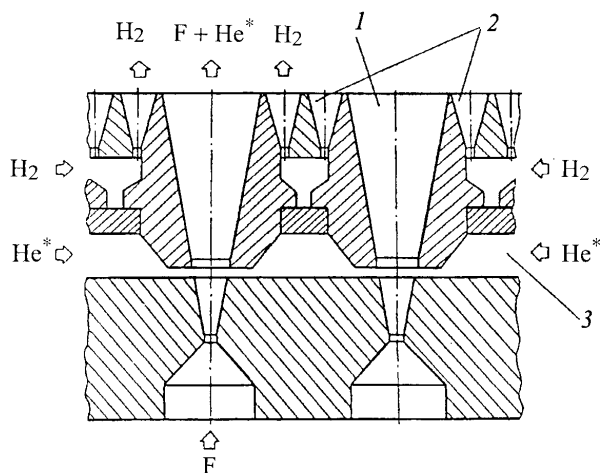

Fig. 1. Two-jet nozzle unit (scheme of mixing with axially symmetric nozzles): 1) oxidizing gas nozzle (84 nozzles); 2) ring nozzle of secondary fuel (hydrogen); 3) channel of feeding secondary diluent (helium).

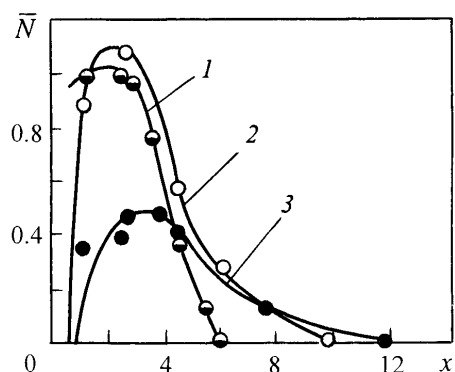

Fig. 2. Longitudinal distributions of normalized laser radiation power: 1) $\psi_2 = 0$, 2) 3, and 3) 14. \bar{N} , rel. units; x , cm.

The present paper is devoted to the investigation of methods for increasing the HF CCL lasing length by additionally diluting the active medium with helium, feeding it to different regions of the oxidizing gas nozzle and active medium. The problem at hand was solved by using models of HF lasers equipped with nozzle units of different designs based on a three-dimensional scheme of mixing components.

Experimental. The investigations were carried out on a test bed comprising a model of an independent kW-class HF laser with a nozzle unit of one of the three types, a system of feeding the working fuel components and recording the regime parameters, and an optical measuring complex. The working fuel components were fed in the molar ratio $D_2:F_2:He:H_2:He^* = 1:\alpha_1:\psi_1(\alpha_1 - 1):\alpha_2(\alpha_1 - 1):\psi_2(\alpha_1 - 1)$. In so doing, the amount of the additional diluent (He^* molecules) was given by the secondary dilution ratio ψ_2 .

Experiments were performed on the basis of a single methodological approach including determination of the generated radiation power distribution along the active medium flow on the basis of which its length and the energy characteristics of the laser were estimated, measurement of the spectral composition of the radiation and beam sizes in the near region, and assessment of the general picture of the active medium flow and its optical quality. In making measurements, we used the following devices and methods: a dual slit cavity [2, 3], a large-aperture stable flat-spherical cavity [3], a high-speed scanning spectrometer [4], a scanning-type beam analyzer [5], thin film burning, a lateral shear interferometer [6], and active medium filming in the visible region of the spectrum [7, 8].

Experimental Results. *Scheme of mixing with axially symmetric nozzles.* One of the methods of additional dilution of the active medium with an inert gas providing certain possibilities for controlling the HF CCL characteristics (including the lasing length) is a modified two-jet scheme of mixing in which secondary helium is fed into the supersonic parts of the oxidizing gas nozzles. Such a method was realized by us in the structure of a nozzle unit with axially symmetric nozzles [9] according to which in the supersonic parts of nozzles 1 (Fig. 1) in the plane close to the critical section there is a clearance 3 for feeding secondary inert diluent (He^* molecules). Owing to the ejecting action of the jets of the oxidizing gas, the latter is carried along into the supersonic parts of nozzles 1, spreading over their walls and forming at the exit from the nozzle unit an interlayer separating the jets of F atoms and H_2 molecules analogously to the three-jet scheme of mixing. The nozzles 1 are arranged in three rows with a spacing of 8 mm; the outlet cross section of the nozzle unit is 23×2.4 cm.

Figure 2 shows the experimental dependences of the normalized laser radiation power \bar{N} on the distance x from the exit section of the nozzle unit to the optical axis of the cavity (normalization was carried out on the basis of the maximum radiation power obtained at $\psi_2 = 0$). From their comparison it is seen that upon feeding the additional inert gas ($\psi_2 > 0$) both the beginning of the lasing region and the region of the active medium with maximum

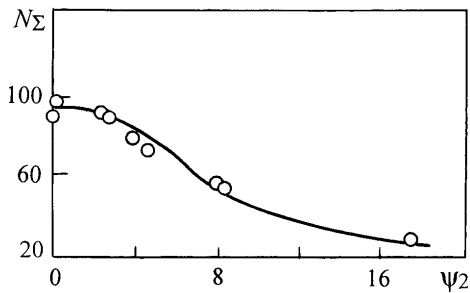

Fig. 3. Specific energy output of the HF laser versus the secondary dilution ratio. N_Σ , J/g.

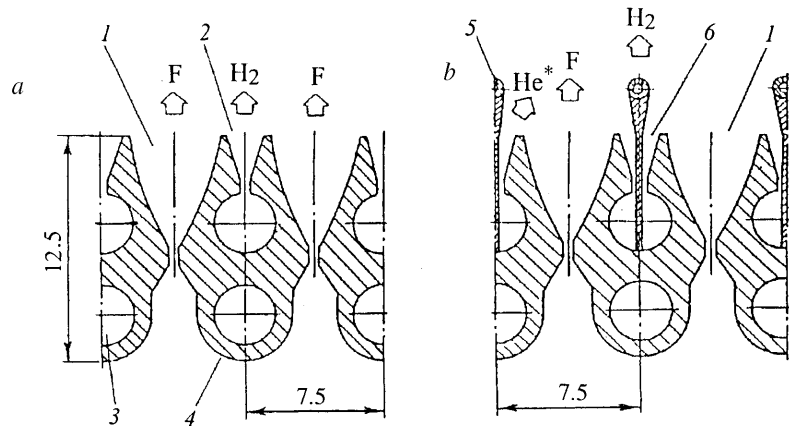

Fig. 4. Two-jet (a) and three-jet (nozzle–nozzle–injector scheme of mixing) (b) nozzle units: 1) oxidizing gas nozzle (33 nozzles); 2) hydrogen nozzle; 3) cooler (water) channel; 4) nozzle vane; 5) hydrogen injector; 6) helium nozzle.

lasing properties have shifted down the stream from the outlet cross section of the nozzle unit. In so doing, the active medium length has increased from 6.5 to 9–11 cm (depending on the amount of secondary helium).

Comparison of the data obtained with the active length of the HF laser equipped with a conventional slit two-jet nozzle unit corresponding to the nozzle–nozzle scheme of mixing with an analogous spacing reveals its increase by a factor of 1.3 to 1.6. It is also seen from Fig. 2 that the mode of operation with additional dilution (curve 2) makes it possible to somewhat increase the laser radiation power as well (in this case, by about 10%).

The dependence of the specific laser energy output on the dilution ratio ψ_2 is shown in Fig. 3 (in this case, the optical axis of the cavity was positioned at a distance of $x = 2.5$ cm from the exit section of the nozzle unit in the region of maximum lasing properties). If the lasing power of the laser reaches its maximum ($N_{\max} \sim 1$ kW) at values of $\psi_2 = 1.5$ – 2.5 , the specific energy output N_Σ remains practically unaltered up to a value of $\psi_2 \sim 3$ and noticeably decreases at larger secondary dilution ratios.

Analysis of the interferograms of the active medium flow has revealed the presence of sinusoidal distortions of the interference fringes corresponding to the three rows of nozzles of the nozzle unit. These distortions are small, which may point to an acceptable optical quality of the gas flow. As a result of the calculation performed for a 5×5 cm aperture and a radiation wavelength of $\lambda = 3 \mu\text{m}$ at $\psi_2 = 3$ (optimum from the point of view of the maximum laser radiation power), we obtained a Strehl number of $\text{Sh} = 0.91$, which significantly exceeds that in the flow formed by a nozzle unit of a similar structure but without secondary dilution with helium [9].

Thus, it is shown that the modified two-jet scheme of mixing with feeding of an additional amount of helium into the supersonic sections of the oxidizing gas nozzles can be of certain practical interest from the viewpoint of the possibility of controlling the lasing length. Moreover, in such a structure two more important results are realized: avoidance of catalytic recombination of atomic fluoride on the walls of the supersonic section of the oxidizing nozzles and protection of the supersonic section of the oxidizing nozzle against corrosion due to the exclusion of contact of its walls with chemically active components.

Three-jet scheme of mixing. The principle of three-jet mixing in pure form (with spatial separation of the jets of fuel components) has been realized by us in two structures of nozzle units differing in the scale and method of feeding of the additional inert diluent.

Nozzle–nozzle–injector scheme of mixing. Such a scheme involves secondary helium feeding directly into the region of active medium formation. The nozzle unit corresponding to this scheme [10] is a modernized version of the conventional two-jet slit nozzle unit (Fig. 4a). In this case, in each secondary fuel (H_2) nozzle 2 a V-shaped element with an injector is set. It is 1 mm in diameter and is made of stainless steel in the form of a tube 5 with perforated holes (Fig. 4b). The secondary fuel was fed through 13 holes $0.3 \mu\text{m}$ in diameter spaced 2 mm apart in the perforated

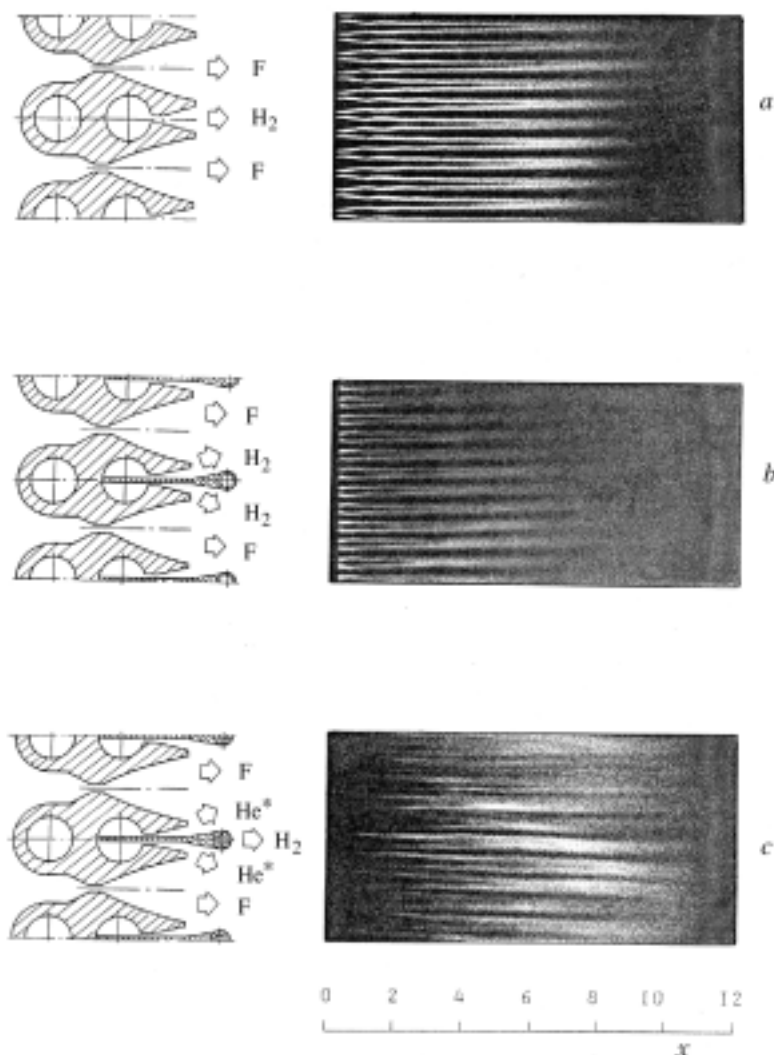

Fig. 5. Mixing schemes and pictures (cinograms) of the active medium flow: a) behind the two-jet nozzle unit; b) behind the nozzle unit in which the hydrogen injectors were replaced by solid tubes; c) behind the three-jet nozzle unit ($\psi_2 = 20$). x , cm.

tube, and the nozzle 6 divided by a V-shaped element into two sections was used to feed secondary helium (He^* molecules). The nozzles are spaced 7.5 mm apart, and the size of the output cross section of the nozzle unit is 25×2.8 cm.

One can get a general idea of the flow pattern of the active medium from the results of its filming. Figure 5a shows the scheme of mixing and its corresponding typical flow pattern behind the exit section of the two-jet nozzle unit. The flow structure observed in the photograph is a combination of alternating dark and light areas. The dark rapidly degenerating areas correspond to the initial section of the oxidizing gas jets flowing out through the oxidizing nozzles. The extended dark areas correspond to the cold hydrogen jets flowing out of the secondary fuel nozzles. The light areas (luminescent front) originating in the plane of the exit section of the nozzle unit at the place of contact of the fluoride and hydrogen jets are the areas of mixing and proceeding of the chemical reaction of pumping. These areas, gradually shifting into the oxidizing gas flow and reaching its axis, characterize, to a certain extent, the lasing length [7, 8].

Since the two-jet nozzle unit (Fig. 4a) was transformed into a three-jet one (Fig. 4b) by means of V-shaped elements with injectors, to estimate the influence of these elements on the flow, we performed experiments with re-

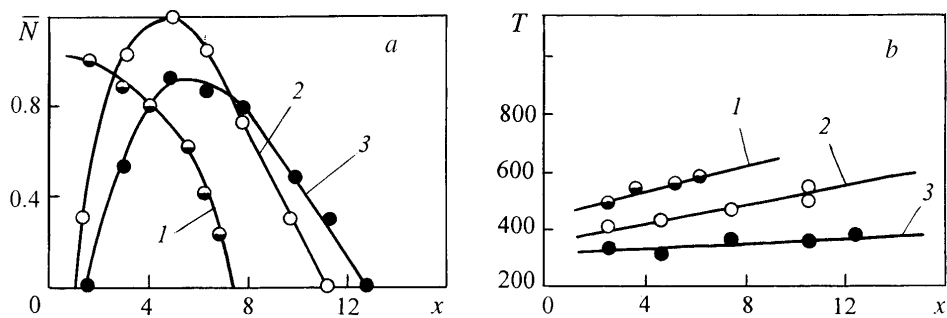

Fig. 6. Longitudinal distributions of normalized laser radiation power (a) and translational temperature (b): 1) two-jet nozzle unit; 2) three-jet nozzle unit ($\psi_2 = 5$); 3) ($\psi_2 = 20$); \bar{N} , rel. units; T , K; x , cm.

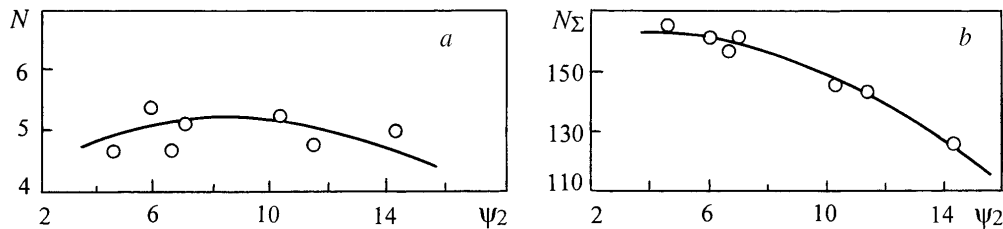

Fig. 7. Dependences of the radiation power (a) and specific energy output (b) of the HF laser with a three-jet nozzle unit on the secondary dilution ratio. N , kW; N_Σ , J/g.

placement of injectors by solid tubes (in so doing, hydrogen was fed into the nozzles divided by V-shaped elements — Fig. 5b). From a comparison of the cinegrams in Fig. 5a and b, it is seen that the length of the light areas in the second case has decreased. This fact is likely to be due to a certain intensification of mixing due to the transverse velocity component of the secondary fuel jet that arises when the jet passes over a V-shaped element. The flow pattern formed by the three-jet nozzle unit is shown in Fig. 5c. Despite the presence of V-shaped elements, it demonstrates a larger length of light areas and a shift of their origin downstream from the exit section of the nozzles.

Measurements of the longitudinal radiation power distribution have shown that the active medium retains its lasing properties at a distance of $x \sim 12.5$ cm from the exit section of the nozzle unit (Fig. 6a). The translational temperature distributions, calculated by the radiation spectra under the assumption of equilibrium of rotation states, in the active media formed by both nozzle units indicate that the addition of helium directly into the region of active medium formation in the three-jet nozzle unit leads to a decrease in its temperature (Fig. 6b).

The influence of the secondary dilution ratio on the energy characteristics of the HF laser with a three-jet nozzle unit is illustrated in Fig. 7. As the ratio ψ_2 increases, the laser radiation power increases, reaching its maximum value at $\psi_2 = 7.2$. At the same time, as one would expect, the specific energy output, remaining practically unchanged up to $\psi_2 \sim 5$, begins to decrease markedly at larger secondary dilution ratios. The chemical efficiency η of the HF laser behaves as follows (Fig. 8): in the case of the two-jet scheme of mixing, as the total dilution ratio $\psi_\Sigma = \psi_1 + \psi_2$ increases, it increases initially until a definite maximum value is reached and then begins to decrease sharply. Such a character of change in the efficiency is likely to be due to the fact that in the laser with a two-jet nozzle unit an increase in the mass flow of the diluent fed exclusively into the atomic fluoride generator leads to a decrease in the temperature in both the active medium and the generator. A decrease in the active medium temperature leads to an increase in the partial inversion and, consequently, in the efficiency, whereas a decrease in the fluoride temperature in the generator (especially below 1500 K) promotes growth of losses of the latter in the elements of the gas-dynamic channel of the laser and, naturally, decreases its efficiency. It is different with the laser with a three-jet nozzle unit where, without decreasing the fluoride temperature in the generator, it is possible to decrease only the active medium temperature owing to the possibility of feeding an additional quantity of helium between the jets of components at the optical cavity input, which leads to an increase in the chemical efficiency and the lasing length.

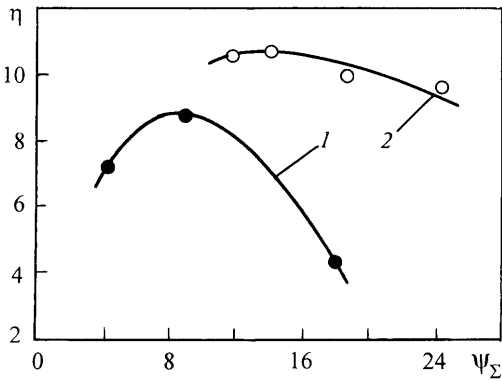

Fig. 8. Chemical efficiency of the HF laser versus the total dilution ratio for the two-jet (1) and three-jet (2) nozzle units. η , %.

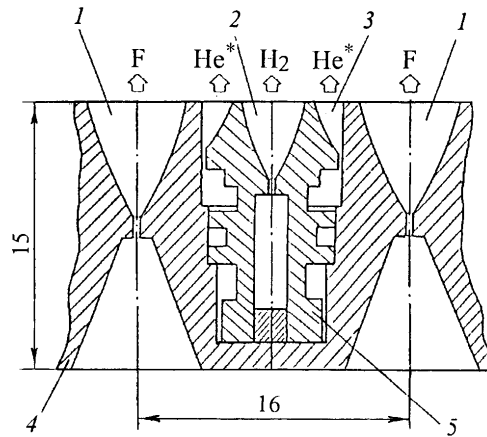

Fig. 9. Three-jet nozzle unit (nozzle–nozzle–nozzle scheme of mixing): 1) oxidizing gas nozzle (25 nozzles); 2) secondary fuel (hydrogen) nozzle; 3) secondary diluent (helium) half-nozzle; 4) housing; 5) insert-pylon.

The energy characteristics of the laser with a three-jet nozzle unit in varying the overall mass flow rate of components m proved to be higher than in the laser with a two-jet nozzle unit. For instance, in particular, the maximum power for the first scheme was $N_{\max} = 8.2$ kW and for the second scheme $N_{\max} = 6.1$ kW. A maximum specific energy output of 225 J/g was obtained for the laser with a three-jet nozzle unit at $m = 18$ g/sec. In these conditions, to the two-jet nozzle unit there corresponds a specific energy output of 180 J/g.

It should be noted that the above characteristics are not limiting and can be increased. In particular, for the model of the HF laser with a three-jet nozzle unit of the type of nozzle–nozzle–injector the simplest method for such an increase consists of intensifying the process of mixing the secondary fuel jets with the oxidizing gas flow by injecting them at an angle to the direction of the latter. Obviously, in this case (compared to the parallel injection — Fig. 4b) the active medium length should change. As a result of the experimental investigation of this question, we have established that intensification of the process of mixing by injecting H₂ molecules at an angle of 20° into the flow of F atoms makes it possible to reach the specific energy output maximum at a mass flow rate of hydrogen 20% smaller as compared to the parallel injection and increase the specific energy output by 12% with a 15% decrease in the lasing length.

As for the optical quality of active media, the level of optical inhomogeneities in the active medium formed by the three-jet nozzle unit (Fig. 4b) proved to be 30% (in terms of the Strehl number) lower than in the active medium formed by the two-jet nozzle unit (Fig. 4a).

Thus, the results obtained by us in the course of detailed experimental studies of the model of the HF laser with a three-jet nozzle unit based on the nozzle–nozzle–injector scheme of mixing have convincingly demonstrated the possibility of realizing most of the advantages of the mode of operation with additional dilution of the active medium by feeding helium directly into the region of its formation.

Nozzle–nozzle–nozzle scheme of mixing. This scheme also involves feeding of the secondary diluent directly into the region of active medium formation. Its principal distinction from the previous scheme is that all fuel components are fed through slit nozzles whose output cross sections lie in the same plane. This fact facilitates the solution of problems associated with numerical simulation [11].

The nozzle unit of the HF laser model corresponding to the nozzle–nozzle–nozzle scheme of three-jet mixing of components (Fig. 9) comprises a housing 4, in which contoured supersonic nozzles 1 spaced 16 mm apart are provided for feeding the oxidizing gas (F atoms), and a set of inserts-pylons 5. In the central part of each pylon, there is a supersonic slot nozzle 2 for feeding the secondary fuel (H₂ molecules) and the peripheral parts of the pylon form with the walls of the recesses in the housing 4 two supersonic slit half-nozzles 3 for feeding the secondary diluent

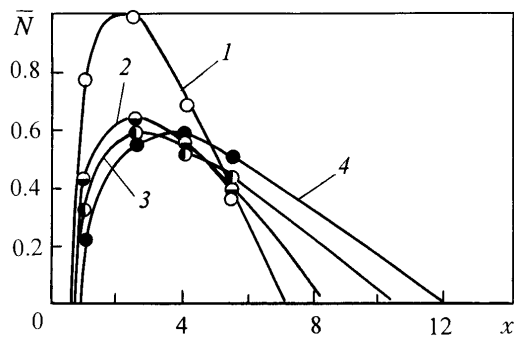

Fig. 10. Longitudinal distribution of normalized laser radiation power: 1) $\psi_2 = 0$, 2) 3, 3) 5, and 4) 10. \bar{N} , rel. units; x , cm.

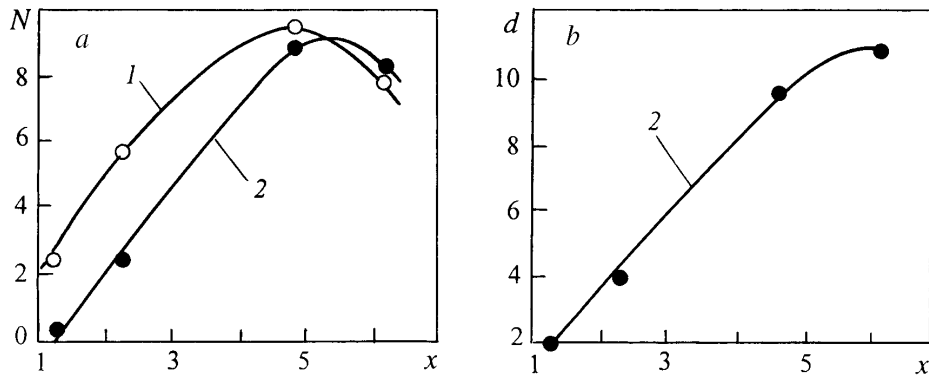

Fig. 11. Derived power and width of the near region of radiation (as to thin foil burning) (b) of the HF laser versus the position of the large-aperture cavity axis relative to the exit section of the nozzle unit. 1) $\psi_2 = 0$; 2-5. N , kW; d , cm; x , cm.

(He^* molecules) separating the fluoride and hydrogen flows [3]. The size of the output cross section of the nozzle unit is 40×11 cm.

The results of measurements of the longitudinal radiation power distribution made by means of a dual slit cavity show that in the absence of secondary helium feeding ($\psi_2 = 0$), the active medium retains its lasing characteristics at a distance of $x \sim 7$ cm from the exit section of the nozzle unit (Fig. 10). It should be noted that the region of the active medium exhibiting the maximum lasing characteristics corresponds to the coordinate $x = 2$ cm. When the secondary diluent is fed, this region shifts downstream (to the coordinate $x = 4$ at $\psi_2 = 10$), the origin of the lasing region is "edged" from the exit section of the nozzle unit by about 1 cm and its length reaches 11 cm. These facts are corroborated by the results of filming the active medium flow field in the direction perpendicular to the optical axis of the cavity (Fig. 12). As seen from the cinegrams, even in the case of a not very large secondary dilution ratio ($\psi \sim 5$) the origin of the lasing region is somewhat "edged" from the exit section of the nozzle unit.

Measurements of the HF laser radiation power depending on the position of the optical axis of the large-aperture cavity relative to the exit section of the nozzle unit have shown the following (Fig. 11a). In the absence of secondary dilution with helium the radiation power reaches its maximum value $N_{\text{max}} = 9.5$ kW at $x = 4.5$ cm. The presence of secondary dilution ($\psi_2 = 5$) causes a 1-cm shift of the optical axis down the stream of the active medium flow. In this case, the N_{max} value changes insignificantly and the specific energy output decreases from 91 to 80 J/g. The moderate specific energy output is largely due to the large nozzle array spacing (16 mm) whose decrease should promote growth of the laser's energy characteristics.

The near region of radiation is characterized by the width d — the laser beam size in the direction of the active medium flow measured in the plane of the output mirror of the cavity. The dependence of the width d (determined by the thin foil burning) on the position of the cavity optical axis at $\psi_2 \sim 5$ is given in Fig. 11b. It demonstrates the proportional character of the relationship between the size of d and the position of the x axis. The recorded

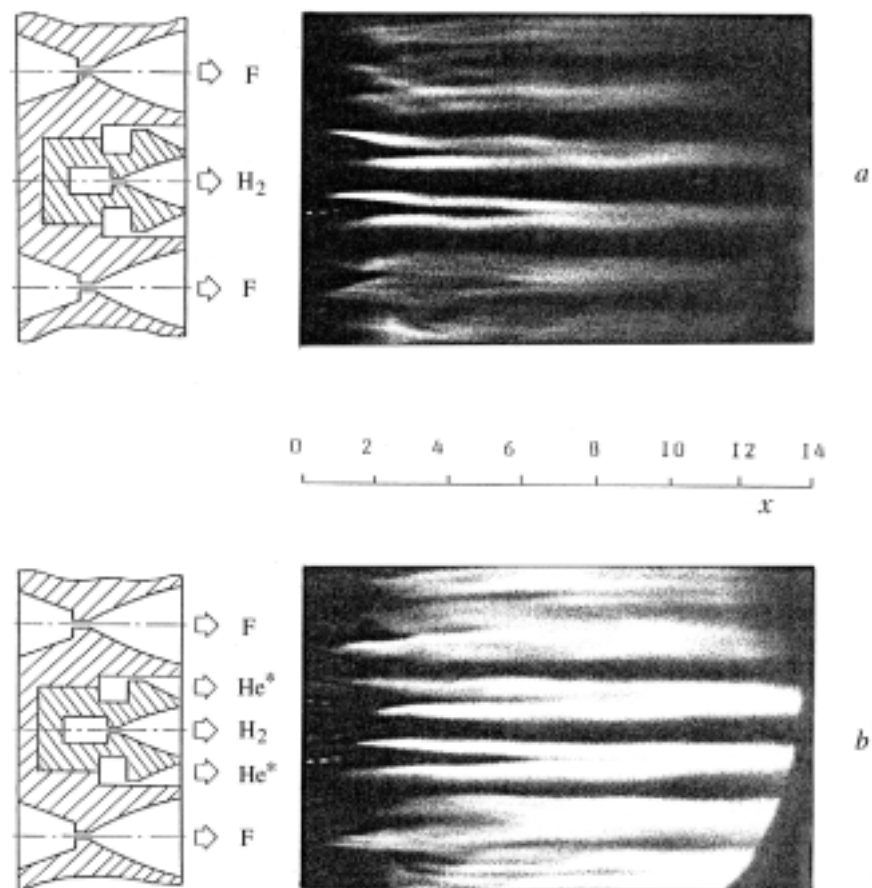

Fig. 12. Pictures (cinigrams) of the active medium flow behind the nozzle unit: a) $\psi_2 = 0$; b) 5; x , cm.

length of the near region of radiation was no less than 10 cm. The measurement data obtained by scanning the image of the near region by the beam analyzer fairly well coincided with the sizes determined by the thin foil burning. Since the height of the near region is 11 cm, this fact indicates that for the first time in the use of HF CCLs we managed to obtain an output beam with a cross section close to a square one measuring 10×11 cm.

The optical quality of the active medium estimated by varying the ratio ψ_2 in the range of $\psi_2 = 4-8$ proved to be fairly high. The Strehl number was $Sh = 0.92-0.95$, with the larger value of the number pertaining to a higher degree of secondary dilution.

Conclusions. Our experimental studies on the methods of increasing the lasing length of HF LCCs have shown that the most effective method is the active medium dilution with an inert gas (helium) by feeding it directly into the region of active medium formation with the aid of nozzle units based on the principle of three-jet mixing of fuel components. The use of such nozzle units makes it possible to almost double (increase up to 12.5 cm) the lasing length, simultaneously upgrading its optical quality and increasing the laser energy characteristics (compared to the two-jet nozzle unit). As a result of the realization of the first of these possibilities, we managed to obtain a large-aperture 10×11 cm output beam with a cross section close to a square one, which gives hope for facilitating the operating conditions of the system of real laser beam formation and focusing.

NOTATION

$\alpha_1 = n_{F_2}/n_{D_2}$, oxidizer excess factor; $\alpha_2 = n_{H_2}/(n_{F_2} - n_{D_2})$, hydrogen excess factor; $\psi_1 = n_{He}/(n_{F_2} - n_{D_2})$, dilution ratio in the atomic fluoride generator; $\psi_2 = n_{He}/(n_{F_2} - n_{D_2})$, secondary dilution ratio of the active medium; n_i , molar rate of flow of the i th component, mole/sec; ψ_Σ , total dilution ratio; X , coordinate along the direction of the active me-

dium flow, cm; N , absolute laser radiation power, kW; $\bar{N} = N/N_{\max}$, normalized laser radiation power; N_{Σ} , specific laser energy output J/g; λ , wavelength, μm ; Sh, Strehl number; m , total mass flow of fuel components, g/sec; d , laser-beam size in the direction of the active medium flow, cm; T , translational temperature, K; η , chemical efficiency, %.

REFERENCES

1. R. I. Soloukhin and N. A. Fomin, *Gas-Dynamic Lasers of the Mixing Type*, [in Russian], Minsk (1984).
2. I. I. Galaev, S. V. Konkin, V. K. Reboné, and I. A. Fedorov, *Prib. Tekh. Éksp.*, No. 1, 122–124 (1997).
3. S. V. Konkin, V. K. Reboné, M. A. Rotinyan, I. A. Fedorov, A. P. Adzhyan, A. A. Belyaev, V. G. Karel'skii, Yu. P. Maksimov, and N. A. Pirogov, *Kvantovaya Élektron.*, **25**, No. 5, 397–400 (1998).
4. S. A. Dolin, N. A. Kruegle, and J. A. Penzias, *Appl. Opt.*, **6**, 267–274 (1967).
5. D. Malakar (ed.), *Optical Production Control* [Russian translation], Moscow (1985).
6. A. S. Bashkin, P. I. Korotkov, Yu. P. Maksimov, N. A. Pirogov, A. Yu. Rodionov, V. E. Smirnov, A. A. Stepanov, S. V. Troshchenkov, and V. N. Shekhtman, *Kvantovaya Élektron.*, **24**, No. 9, 786–790 (1997).
7. R. L. Varwig, *AIAA J.*, **12**, No. 10, 1448–1450 (1974).
8. J. Driscoll and G. W. Tregay, *AIAA J.*, **21**, No. 2, 241–246 (1983).
9. A. S. Boreisho, S. V. Konkin, V. V. Lobachev, A. V. Morozov, V. L. Moshkov, V. K. Reboné, and I. A. Fedorov, *Kvantovaya Élektron.*, **24**, No. 6, 487–496 (1997).
10. I. I. Galaev, S. V. Konkin, A. M. Krivitskii, V. K. Reboné, M. A. Rotinyan, N. E. Tret'yakov, and I. A. Fedorov, *Kvantovaya Élektron.*, **21**, No. 3, 217–221 (1996).
11. M. A. Rotinyan, M. Kh. Strelets, I. A. Fedorov, and M. L. Shur, *Kvantovaya Élektron.*, **25**, No. 5, 387–391 (1998).